

## Research on teaching reform of a provincial course: *Foundation and Application of SCM*

Tongcheng Huang, Xu Duan, Shiming Jiang & Liping Yin

Shaoyang University  
Shaoyang, People's Republic of China

**ABSTRACT:** The authors of this article present a study on teaching reform of a degree course for the foundation and application of single chip micro-computer (SCM) technology at a provincial institution, based on relevant studies in China and abroad. A *Foundation and Application of SCM* course is offered to students majoring in various engineering degree programmes. In this article, the authors describe the course development, its features, and the achievements of the course transformation and popularisation. Remaining problems and challenges, together with further research directions, are also raised and discussed.

### INTRODUCTION

Single chip micro-computer (SCM) technology is an important branch of computer technology. *Foundation and Application of SCM* is an important professional basic course in engineering majors, such as electronics, electrical engineering, computers, automation, mechanical and electrical integration, and mechanical manufacturing.

Widely used in people's life, as well as in industrial and agricultural production, SCM technology has become one of the important parts of an intelligent core in modern electronic systems. Therefore, the application of SCM technology is a necessary basic skill required of engineering and technical personnel in the fields including electronic information and electrical control. Undergraduate students, while learning the course of foundation and application of SCM, carry out chip experiments, but due to the fact that the traditional SCM experimental device is fixed, they could be offered few opportunities for their own exercises. Students, in the whole experimental process, could only follow the device designer's ideas. Instead of being conducive to the cultivation of students' innovation ability, it results in the detrimental situation that colleges' cultivation of innovative ability departs from social needs. After graduation, students have to undertake at least three to five years of intensive training to be able to deal with the micro controller unit (MCU) development and application tasks independently.

For the majority of engineering and technical personnel in the design of MCU application systems, the procedure for the development of traditional microcomputer application systems is as follows: first, undertake circuit and program design, then, design the printed circuit board (PCB), build the required circuits, do some program simulation debugging and, finally, download the program to the CPU (central processing unit) and debug the system. The whole process should be carried out again, if it fails any of the steps [1]. Such a problem is encountered especially in the circuit design phase, during which the process of reiteration can take a long time if a problem arises. How to accelerate the development of SCM? This is the common objective of every product developer.

Based on the above two points, the research group involved germinated ideas to develop modularised SCM experimental devices with a multi-core *building block*. Starting from the theory, the research group went through nearly ten years of research and practice to modularise SCM application systems by optimising and integrating, which is guided by the ideology of applying integrated unit circuit systems to combine the experimental apparatus and developing such apparatus. In the design of a SCM application system, Proteus simulation technology was first introduced to design and simulate the application system in the virtual design environment and, then, to select the module to lap circuits, verify hardware and, finally, to integrate the system.

The successful development of a new device's application for higher education can be aided by reforming the traditional experimental apparatus, as well exploring the training model to generate application-oriented talent. For the

vast majority of developers in single-chip application, it can be designed on a virtual platform, overcoming drawbacks in which debugging cannot be taken out without hardware and, also, a hardware platform can be set up quickly to verify the design, so as to accelerate the product development process. Therefore, the development of this product can be endowed with practical application value and social benefit.

Since the 1970s, SCM has experienced four stages of development: single chip micro-controller exploration stage, single chip micro-controller perfect stage, micro-controller development stage and single chip micro-controller comprehensive application stage. SCM can be developed according to this trend. An eight-bit single chip micro-controller can act as the main body in low-end applications, while a 32 bit single chip micro-controller can act as the main body in high-end applications. The external circuit can be integrated internally. The function of the CPU is enlarged constantly. There are various kinds of SCM. Internet service providers (ISP), downloading technology are popularised, and simple devices with ISP can replace expensive systems. Gaining popularity, SCM applications are closely related to people's life standards [1-4].

Development apparatus and experimental devices are changing along with the pace of SCM development. The 8031 single chip acts as the representative of the 1970s. However, it has no program memory in it, so the program can only be cured into a special memory chip and ultraviolet can be used to erase the program. All the apparatus was imported, costing more than 10,000RMB. In 1980s, the 8051 and 8086 were the main chips. The peripheral circuit was integrated into one board (which is called the single board computer) [5-9]. The price of the development apparatus decreased to 6,000RMB. Before 1990s, only a few people had access to SCM or developed SCM products. After 1990s, especially after 1994, while electronic technology was developing and ISP came into use, development and application of SCM grew fast. The kinds of SCM became more varied, such as 51, PIC, AVR, 430, and so on, so the development apparatus also became more varied [10-14].

At that time, the prices went down quickly. In the 21st Century, there are more kinds of SCM, while SCM application skills are maturing and new changes in SCM development apparatus are being brought about. At present, a variety of experimental systems are being produced by manufacturers all over the country, such as Tianhuang technology and Beijing Dasheng technology. All of these have made a considerable contribution to the application of SCM in China. They are characterised by integrating experimental circuits in one PCB board, so that experimental circuits and experiment contents are arranged in advance; hence, the CPU modular will be changed in order to meet different needs. Beijing Polytechnic Shengda Co. Ltd. first introduced ideas of modularity and launched new products in 2004. The authors bought one set in 2005, which showed better results in education and training. However, it also took integration design away, making only peripheral experiment circuit device modular, while the whole system was still integrated on one PCB board. In 2009, Guangdong Windway Co. Ltd. designed an experimental device modular, putting experimental circuits into modules, which is suitable for students to experiment with, but is not suitable for product development.

## TEACHING REFORM RESEARCH

### Main Key Technologies

First, the apparatus is suitable for students to learn microcontroller technology, as well as to meet the needs of technical personnel to develop devices in order to create a close connection between education and training activities in colleges and social needs. Second, the question arises of how to put circuits in SCM application systems into modules, and make hardware into a *building block*. Third is the question on how to introduce Proteus simulation technologies into the development of SCM application systems and make them visible?

### Research Contents

*Modularisation of application circuits:* an SCM application system is put into modular form, from basic experiments to system design by applying theories into practice with an open idea. A variety of CPU modules with *building block* can be developed, resulting in modularisation of hardware integration.

*Visualisation of application systems:* Proteus simulation technology can be introduced into the SCM teaching experiments and development of SCM application systems. Circuit design, program design and system simulation can be carried out in Proteus. Virtual instruments can be employed to measure and analyse system indexes and to realise system visualisation.

### Research Methods

*Investigation:* because of the shortage of traditional SCM experimental devices and the domestic development situation and direction, the authors put forward the solution plan and technical route after research, in accordance with research purposes and key technologies. These included project planning, designing circuits, producing modules and testing systems.

*Scientific experiment and simulation:* in Proteus, the authors carried out circuit design, program design and system simulation to verify circuit functions and test the main technical parameters of the module with virtual instrument.

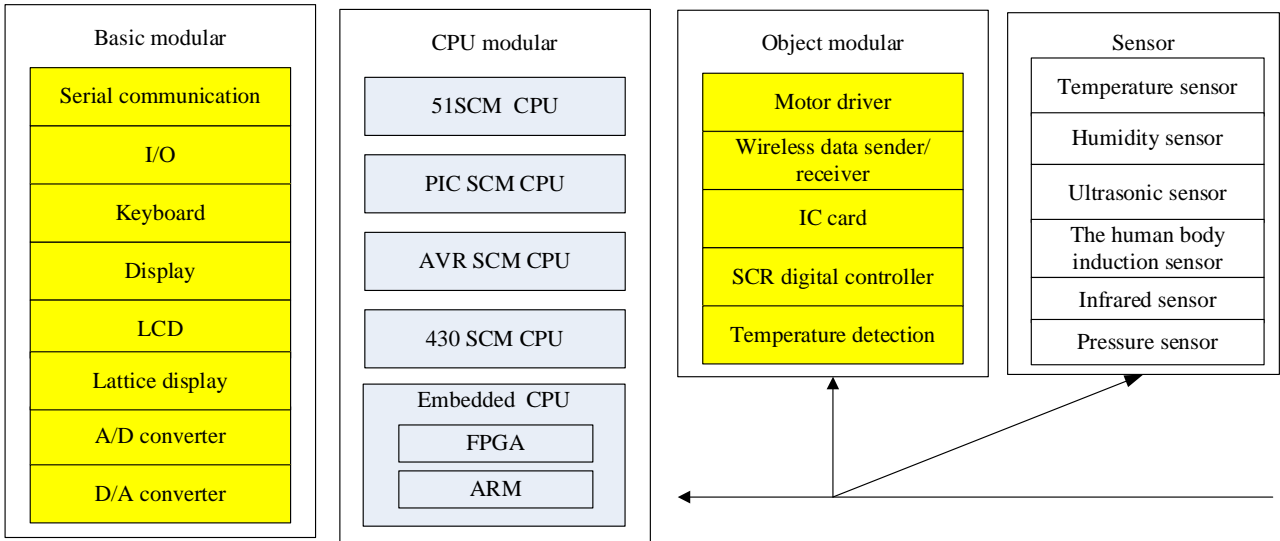

Figure 1: Formulated programme for circuit modularity development.

### Technical Routes for Research

*Design:* the authors first consulted materials about SCM modularisation in order to get a comprehensive view of the development status at home and abroad; then, modularised SCM application circuits and, finally, proposed and verified a technical plan. Figure 1 is the formulated programme for circuit modularity development.

*Circuit design:* module circuits are, then, designed and tested. Figure 2 shows a keyboard module circuit.

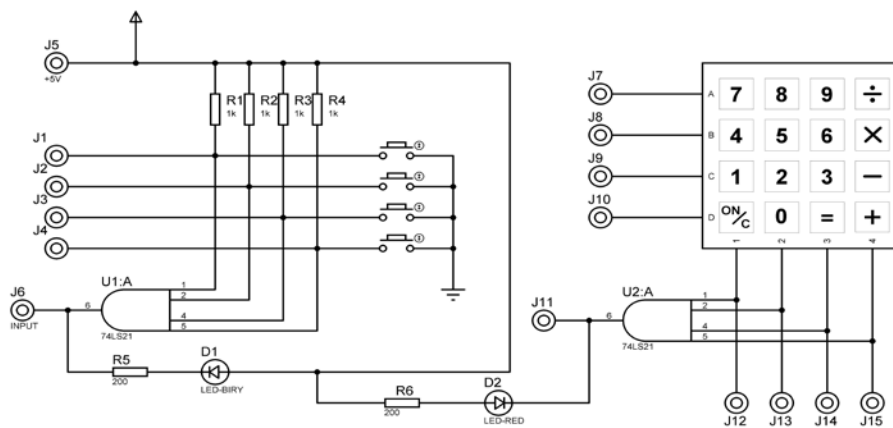

Figure 2: Keyboard module circuit.

*Module:* The PCB board is then designed, made and soldered in circuits to make experiment modules. Figure 3 shows various experiment modules made in recent years.



Figure 3: Experiment modules.

*System test:* modules are selected as laboratory experiment circuits to design test programs and verify each module. Figure 4 demonstrates the verification keyboard and 12864 displaying module.

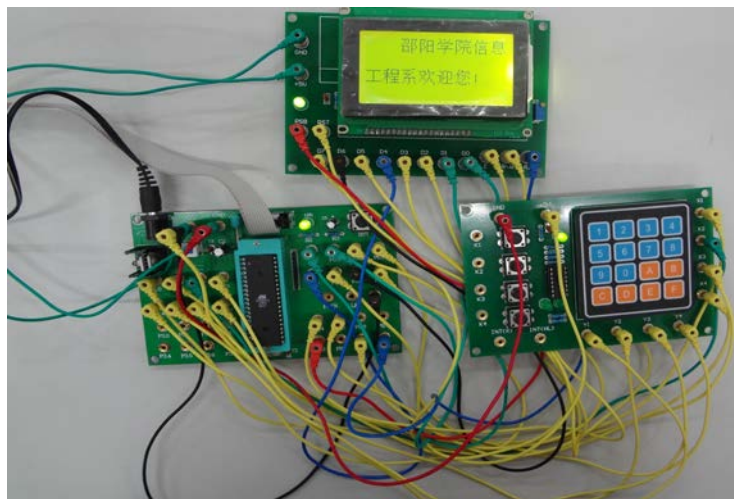

Figure 4: Module verification.

### Key Technical Problems Solved

Firstly, guided by ideas of unit integration systems, the authors combined experimental apparatus with development ones. Through optimisation and integration, the SCM application system reached a state of modularisation, and multi-CPU modules came out of design. Not only does it successfully set *building blocks* among hardware circuits in the application system, it also enables students to fulfil tasks of developing an SCM application system, which bridges college training and the needs of society.

Secondly, the Proteus simulation technology is introduced into developing SCM application systems, which enables the process of system circuit design, program design and system debugging to be visualised. The days, in which system debugging could not work without a physical prototype have gone.

### RESEARCH ACHIEVEMENTS AND FEATURE WORK

#### Research Achievements

The project has led to a variety of results, such as new apparatus, textbooks, patents, teaching courseware and hardware, teaching achievements, graduation projects and research theses. With the efforts of project members, the group has edited five textbooks, published three theses, been awarded two provincial teaching achievement awards, and developed new SCM application and development apparatus for which the group has obtained a patent.

#### Innovation Points

*Modularisation of application circuits:* the SCM application system is put into modular from basic experiments to system designs by applying theories into practice with an open idea.

*Visualisation of application systems:* Proteus is used to carry out circuit design, program design, system simulation and index analysis.

*Building blocks of application and integration:* modules are selected and composed from lap circuits, download programs and verified functions.

### ACHIEVEMENT TRANSFORMATION AND POPULARISATION

#### Application Prospect

The application of SCM technology has become one of the basic necessary skills of technical personnel in electric majors and measurement and control majors. The achievements of the project (such as five textbooks, three research theses and application of Proteus into SCM system design) provide a valuable background for SCM learners and lovers, while promoting the reform of domestic SCM courses. They are also full of social value.

The SCM application apparatus developed in the project is only new size with *building block* and multi-CPU, which is fully open, merging experiments with development and virtual development with application development. It is good

for experiments in the course of Foundation and Application of SCM in colleges, as well as for technical personnel to develop SCM application systems. More than 6 million students have been recruited, among which over 60% are in science and engineering. The course *Foundation and Application of SCM* is offered to about 40% of those majors. It means that, each year, 1,440,000 ( $600 \times 60\% \times 40\% = 144$ ) people receive training in SCM courses. Therefore, the apparatus developed by the group is a promising college education feature. As for technical personnel, they are able to develop SCM application systems quickly by making use of the apparatus, avoiding troubles caused by thoughtlessness and redesign. In this way, it meets technical personnel's needs. Since the number of SCM developers is large, the apparatus demonstrates excellent market prospects.

#### Results Popularisation

*Textbooks:* the authors have edited five textbooks, of which about 15,000 copies were printed. The Foundation and Application of SCM text, published by China Railway Publishing House, has been adopted by 14 colleges.

*Apparatus:* it was first used in the Information Engineering Department and the Mechanical and Energy Department in Shaoyang University and in Shaoyang Advanced Technical School and, then adopted by more than ten other colleges.

*Simulation technology:* Proteus simulation technology is applied to develop SCM systems all over the country. Members of the project have been invited to deliver academic reports throughout the country.

#### REMAINING PROBLEMS AND FURTHER RESEARCH DIRECTION

##### Remaining Problems

In the past ten years, the group has gone from theories to application to undertake comprehensive research and to practice SCM applications and to take exploration of cultivating SCM talents. The aims have been accomplished, which are represented by a series of achievements. Meanwhile, there still remain some problems to be solved:

*Insufficient number of modules:* modules can fulfil the need in SCM foundation experiments, but there are some deficiencies in meeting the demands of SCM development and application. For example, A/D converter modules with less than 12 bit are installed in the apparatus, which is unable to design measurement product with high precision.

*Low reliability of products:* manual soldering is the main production method. Together with deficient-ageing components, it often causes problems with poor quality contacts.

##### Further Research Direction

The rapid development of electronic technology requires the project group to keep learning, so as to constantly absorb new achievements of modern science and technology, increase the number of modules and improve their technological level. Towards the building block integrated electronic platform, the group should consider analog electronic technology, digital electronic technology, high frequency electronic technology, SCM application technology and embedded applications to develop electronic modules. A variety of simulation technology should be applied to the design platform to design an integrated automatic platform of electronic products.

#### ACKNOWLEDGEMENTS

This article is supported by the Hunan Provincial Natural Science Foundation of China (14JJ7075), the Key Scientific Research Fund of the Hunan Provincial Education Department (13A091), the Key Scientific Research Fund of the Provincial Key Laboratory of Informational Service for Rural Area of South-western Hunan, and the Aid Program for Science and Technology Innovative Research Team in Higher Educational Institutions of Hunan Province.

#### REFERENCES

1. Huang, T. and Jiang, S., On the construction and practice of cubic practical teaching system for IT applied personnel cultivating. *WIT Trans. on Infor. and Communication*, UK: WIT Press (2013).
2. Huang, T. and Liu, X., Research and implementation of dynamic synchronous visual teaching system for data structure algorithms. *Advanced Materials Research*, USA (2012).
3. Jiang, S. and Huang, T., *Foundation and Application of SCM*. China Railway Publishing House (2012).
4. Yang, G., Application of simulation in theory of machines and mechanisms for excellent engineering training. *World Trans. on Engng. and Technol. Educ.*, 12, 2, 209-214 (2014).
5. Yin, Q. and Zhang, J., Improving the teaching effectiveness of an SCM course. *World Trans. on Engng. and Technol. Educ.*, 12, 2, 271-275 (2014).
6. Heikkinen, S., Effects of small-group teaching in an electrical engineering course. *Global J. of Engng. Educ.*, 15, 3, 171-176 (2013).
7. Ni, Z., Experimental teaching reform of MCU. *Research and Exploration in Laboratory*, 25, 7, 843-844 (2006).

8. Chen, L., Teaching reform for microcontroller course. *Research and Exploration in Laboratory*, 27, **9**, 121-123 (2008).
9. Liao, P., Reform of the experimental teaching of single chip microcomputer. *Research and Exploration in Laboratory*, 27, **9**, 121-123 (2008).
10. Ma, Z., *C Language Application Program Designing of Single Chip Microcomputer*. Beijing University Press (2003).
11. Jiao, Z., Discussion on the reform of the course of university's one-chip computer teaching in our country under the new situation. *Higher Education Forum*, 2, **1**, 102-105 (2005).
12. Qin, X., Establishment and development of single chip microcontroller comprehensive experiment. *Experimental Technol. and Management*, **2**, 114-118 (2004).
13. Chen, J., Development of single chip microcontroller experiment system. *China Modern Educational Equipment*, 3, 90-92 (2008).
14. Jiang, S., The construction of modular electronic experimental platform and cultivating the innovative talents. *J. of EEE* (2008).